

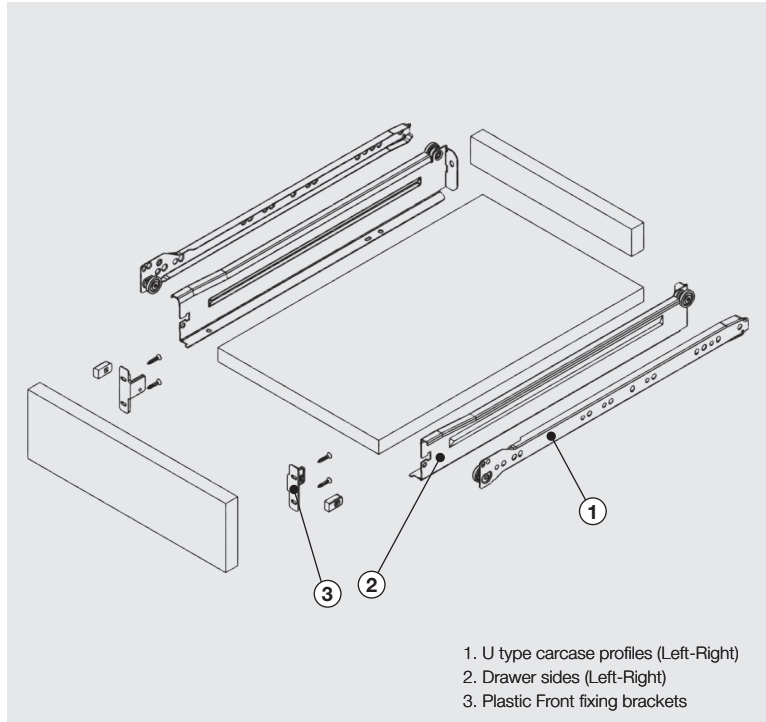

Specifications

- Aesthetic Steel structure
- Automatic closing from 70 mm
- 400/450/500/550 mm size options
- Electrostatic painting (white)
- Special silent wheel system
- Long service life
- 25 kg. loading capacity
- Safety system to prevent drawer falling
- It is possible to adjust drawer surface vertical-horizontal



1-2-3 Drawer Set incl. Screw On Front Connectors

Slide Length	Packing Type	Colour	Code
400 mm.	1 Set	White	6500540
450 mm.	1 Set	White	6500541
500 mm.	1 Set	White	6500542
550 mm.	1 Set	White	6500543

1-2 Drawer Set

Slide Length	Packing Type	Colour	Code
400 mm.	1 Set	White	1121041
450 mm.	1 Set	White	1121051
500 mm.	1 Set	White	1121061
550 mm.	1 Set	White	1121071

3 Front Connector

Material	Packing Type	Type	Colour	Code
Zamac	Pair	Screw On	Nickel	1121801
Zamac	Pair	Dowel	Nickel	1121803

Indicate if you want to substitute screw on with doweled.

Soft Close Mechanism

Packing Type	Colour	Code
1 Set	Grey	6500672

Refer to page C9 for technical information

Required space in the cabinet

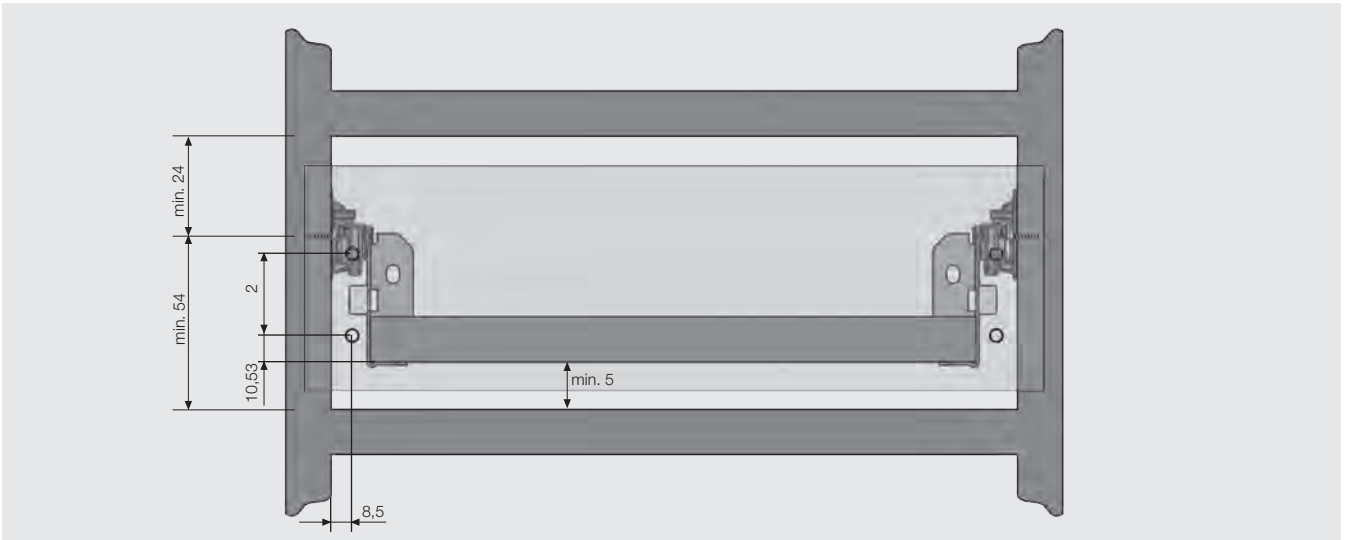

Dimensioning Formulas

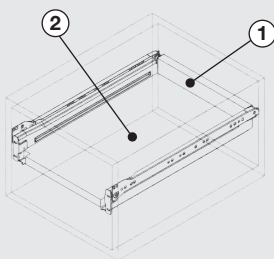

- ①
 Drawer Back Panel width: Cabinet Inner width 31mm(max.33mm)
 Drawer Back Panel Height:min.39 mm (for 16 mm chipboard)
 Drawer Back Panel Height: min 47 mm. (for 8mm chipboard)
- ②
 Drawer wooden floor width=Cabinet Internal width
 - 31mm(max.33mm)
 Drawer wooden floor length=Slide length -1mm

Screw Location Dimensions for slides

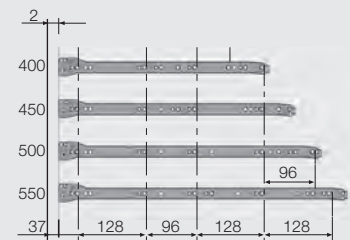

Wooden Back Panel Application

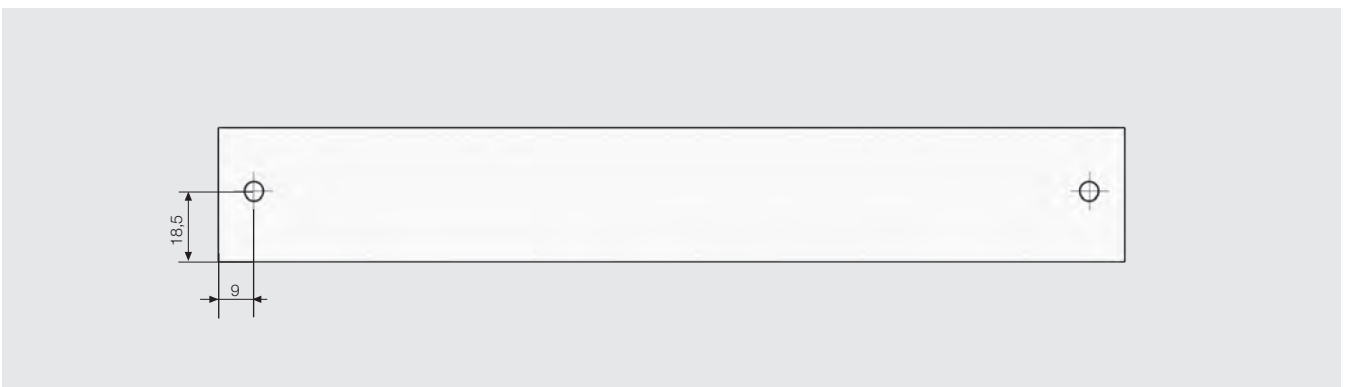

* All dimensions in the diagram are in mm.