

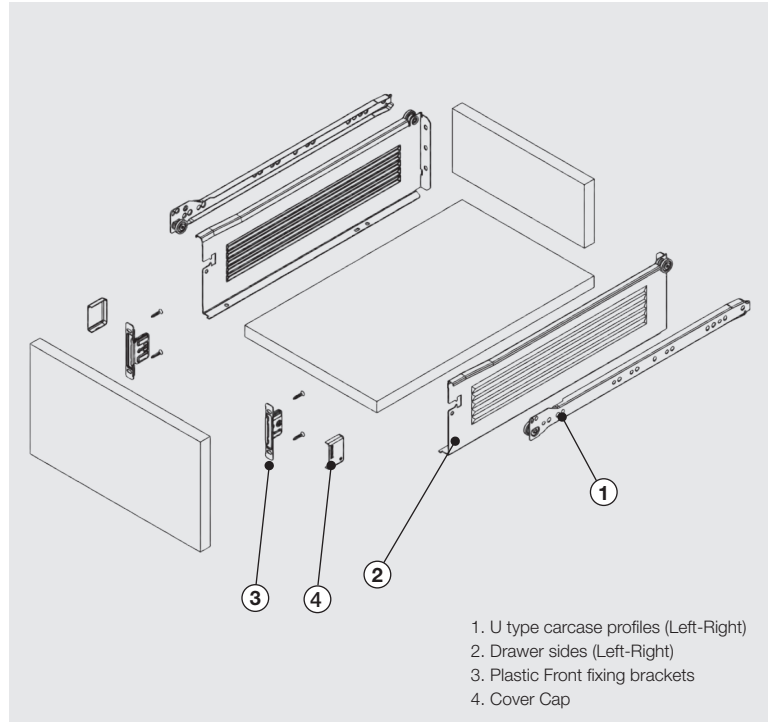

Specifications

- Aesthetic Steel structure
- Automatic closing from 70 mm
- 300/350/400/450/500/550 mm size options
- Electrostatic painting (white)
- Special silent wheel system
- Long service life
- 25 kg. loading capacity
- Safety system to prevent drawer falling
- It is possible to adjust drawer surface vertical-horizontal



1-2-3 Drawer Set incl. Screw On Front Connectors

Slide Length	Packing Type	Colour	Code
300 mm.	1 Set	White	6500610
350 mm.	1 Set	White	6500611
400 mm.	1 Set	White	6500612
450 mm.	1 Set	White	6500613
500 mm.	1 Set	White	6500614
550 mm.	1 Set	White	6500615

1-2 Drawer Set

Slide Length	Packing Type	Colour	Code
300 mm.	1 Set	White	1121221
350 mm.	1 Set	White	1121231
400 mm.	1 Set	White	1121241
450 mm.	1 Set	White	1121251
500 mm.	1 Set	White	1121261
550 mm.	1 Set	White	1121271

3 Front Connector

Material	Packing Type	Type	Colour	Code
Zamac	Pair	Screw On	Nickel	6500670
Zamac	Pair	Dowel	Nickel	6500671

Indicate if you want to substitute screw on with doweled.

4 Cover Cap

Material	Packing Type	Colour	Code
Plastic	Pair	White	1121821

Soft Close Mechanism

Packing Type	Colour	Code
1 Set	Grey	6500672

Refer to page C9 for technical information

Required space in the cabinet

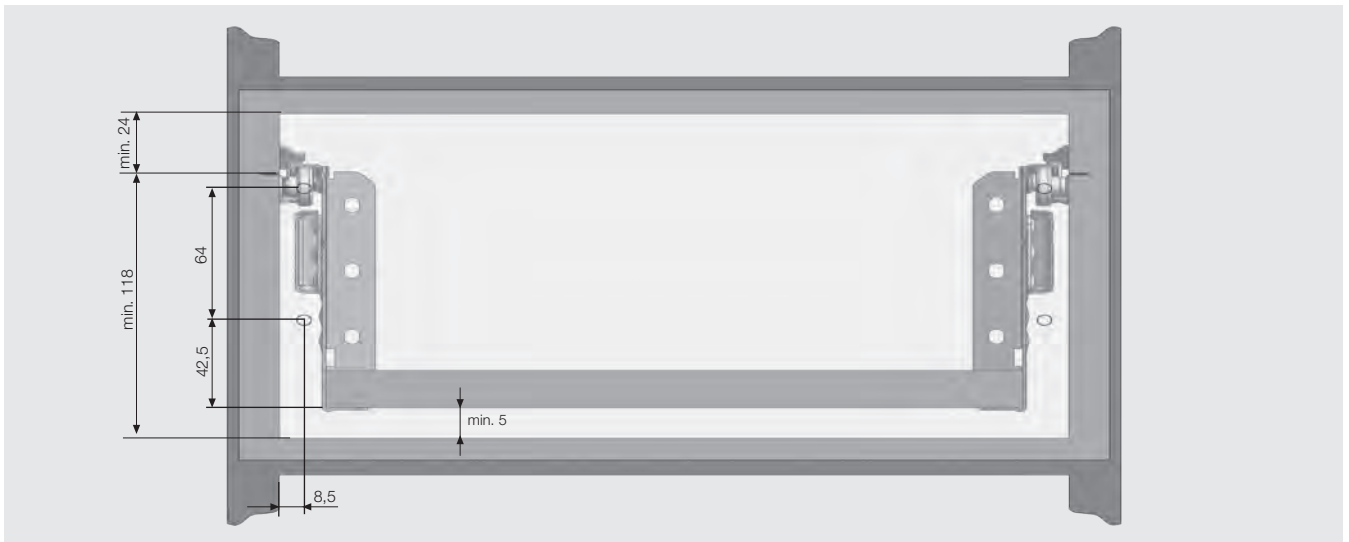

Dimensioning Formulas

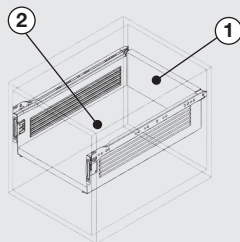

①

Drawer Back Panel width: Cabinet Inner width -31mm(max.33mm)
 Drawer Back Panel Height: min.103 mm (for 16 mm chipboard)
 Drawer Back Panel Height: min 111 mm. (for 8mm chipboard)

②

Drawer wooden floor width=Cabinet Internal width -31mm(max.33mm)
 Drawer wooden floor length=Slide length -1mm

Screw Location Dimensions for slides

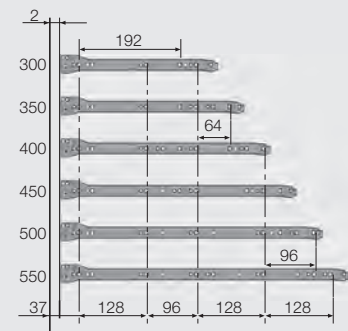

Wooden Back Panel Application

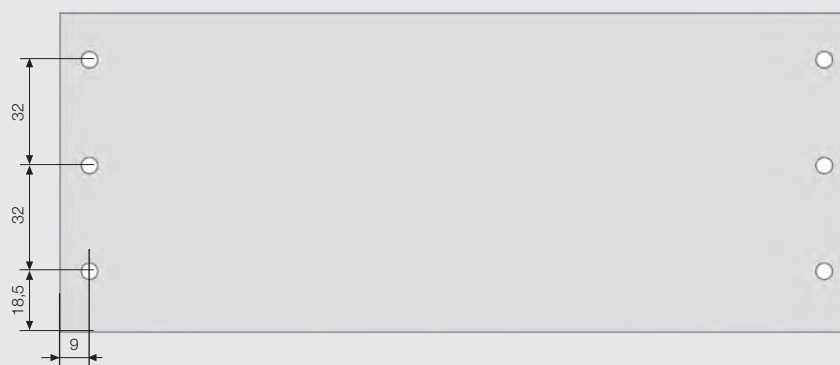

* All dimensions in the diagram are in mm.